

National Electrical Safety Board's regulations and general advice in English – 2008:1

THIS IS NOT LEGAL/JUDICIAL TEXT. This document contains a rough translation of National Electrical Safety Board's regulations. Its contents is not legal text and it should only be used for readers who wish to get a general understanding of the contents in the Swedish regulations concerning electrical safety and electromagnetic compatibility. The texts are not necessarily comprehensive, complete, accurate or up-to-date. For legal text - please use the link below.

Section of legislation: Execution of electrical installations

Number: ELSÄK-FS 2008:1

Amendments per 2017-07-01: Amended by ELSÄK-FS 2010:1 and ELSÄK-FS 2015:3

Title: The National Electrical Safety Board's regulations and general advice on the execution of electrical installations

Legal titel: Elsäkerhetsverkets föreskrifter (2008:1) om hur elektriska starkströmsanläggningar ska vara utförda

Link to regulations: <http://www.elsakerhetsverket.se/om-oss/lag-och-ratt/gallande-regler/Elsakerhetsverkets-foreskrifter-listade-i-nummerordning/elsak-fs-20081/>

Chapter 1 General provisions

1 § These regulations apply to the execution of electrical installations.

The definition of ‘execution’ also includes the modification or extension of an electrical installation.

2 § The regulations do not apply to electrical installations

- in aircraft,
- in vehicles used in electric railway, light rail, underground railway and trolley bus operation,
- in other vehicles including trailers,
- in vessels including leisure craft,
- in other equipment.

General advice

Other vehicles including trailers are taken to mean vehicles such as motorhomes and caravans. Other equipment is taken to mean items such as machinery, hoists and cranes.

3 § In these regulations terms are defined as follows:

general distribution network network covered by a network concession for an area,

restricted access location a room or other location for the operation of electrical installations and other electrical equipment presenting a risk of injury due to electricity,

electric shock harmful effects caused by an electric current passing through the body of a human or an animal,

uninsulated overhead line overhead line with conductors suspended separately from each other with accessories such as insulators and fastenings,

barrier something which prevents accidental contact but which does not prevent deliberate contact,

high voltage nominal voltage over 1000 V AC or over 1500 DC,

<i>earthing point</i>	part of the conducting mass of the earth, with earth electrodes and surrounding backfill,
<i>contact line</i>	a conductor above ground fixed to masts or other supports (e.g. uninsulated overhead line, return line, bypass line, supply line or auxiliary power line or conductor rail) intended for railway, light rail, underground railway and trolley bus operation,
<i>overhead line</i>	conductor or cable above ground fixed to masts or other supports,
<i>low voltage</i>	nominal voltage up to 1000 V AC or up to 1500 V DC,
<i>mechanical line</i> similar equipment,	line for operation of cable cars, ski lifts and
<i>nominal voltage</i>	the voltage for which an installation or part of an installation is designed,
<i>PEN conductor</i>	a directly earthed conductor with a combined earth and neutral function,
<i>live part</i>	conductor or conductive part designed to be energised during normal use, including neutral conductors but excluding PEN conductors,
<i>electrical installation</i>	installation with a voltage, current or frequency that may be hazardous for people or property,
<i>TN system</i>	a distribution system in which a point in the system is directly earthed near the power source and exposed parts are directly connected to this point,
<i>exposed part</i>	conductive part of electrical equipment that can be touched and that is not normally energised but may become energised due to an insulation fault,

socket outlet fixed or movable connector equipped with sockets for the delivery of power (e.g. wall, floor and light socket outlets).

4 § The National Electrical Safety Board may grant exemptions from these regulations.

Chapter 2 Good electrical safety practices

1 § An electrical installation shall be executed in compliance with good electrical safety practices in order to provide adequate safety from injury or damage caused by electricity.

Good electrical safety practices are taken to mean the application of these regulations and of the practices that are otherwise established in the field of electrical safety in supplementary standards or other criteria.

If Swedish standards are applied as a supplement to the regulations, the installation is assumed to have been executed in compliance with good electrical safety practices unless it can be shown otherwise. If the execution of an installation deviates entirely or partly from Swedish standards, the criteria on which the execution was based shall be documented.

2 § Before a new, modified or extended electrical installation is put into service, it shall be checked to ensure it is in compliance with good electrical safety practices. An installation is considered to be put into service when it is energised with a voltage, current or frequency that may be hazardous for people or property. This also applies if the installation is energised temporarily, e.g. for trial operation.

Chapter 3 Fundamental safety requirements

1 § An electrical installation shall be executed so as to provide adequate safety under normal conditions, in the event of one (1) fault in the installation, and in the event of reasonably foreseeable incorrect operation.

2 § An electrical installation shall be executed so as to protect people and domestic animals from electric shock caused by direct contact with live parts or exposed parts that have become live due to a fault – in other words indirect contact.

3 § An overhead line or contact line shall be executed and routed such that its construction and location adequately prevent any risk of injury or damage caused by electricity. It shall be routed an adequate distance from the ground, vegetation, thoroughfares, buildings, etc.

4 § A restricted access location shall be adequately enclosed or fenced off. Only skilled persons or persons who have received instruction on the risk of injury or damage caused by electricity shall be given access to a restricted access location.

5 § An electrical installation shall be executed such that it presents no risk of injury or damage due to high temperatures, arcing or mechanical stresses caused by current during normal operation or overcurrent.

6 § An electrical installation shall be executed so as to withstand the normal voltages expected to occur in the installation and at the transition between live parts in circuits with different voltages.

7 § The execution of an electrical installation shall be determined on the basis of the external conditions in the surrounding area.

General advice

The execution should take account of

- the surrounding environment to the extent that it influences the electrical installation,
- the functions to be performed by the electrical installation and the activities taking place near the electrical installation, and
- in the case of installations in a building, the construction of the building with regard to fire safety and the choice of building material.

8 § An electrical installation shall have with the marking and documentation necessary in order to allow the parts of the installation to be clearly identified for operation and maintenance. The documentation shall be provided in Swedish unless another language is more suitable from the point of view of electrical safety.

9 § An electrical installation shall be executed such that work on the installation can be carried out safely.

Chapter 4 Special safety requirements for low voltage installations

1 § In electrical installations for low voltage it is not permitted to use the method of protection known as ‘insulated environment’ to protect against electric shock from indirect contact unless particular circumstances make this method necessary.

2 § General distribution networks for low voltage shall be executed as TN systems. The PEN conductor of the system shall be earthed near the power source and in overhead line networks additionally at suitable places at the network extremities.

3 § Mains socket outlets in low voltage installations shall either be equipped with safety covers or executed or positioned to limit the risk of accidents involving children.

3 a § Mains socket outlets for household and similar purposes in low voltage installations shall meet the requirements in the National Electrical Safety Board's regulations (2015:1) on plugs and socket outlets for household and similar purposes, or regulations that have replaced them.

4 § In the case of installations in buildings containing dwellings, primary schools, kindergartens, leisure centres or daycare centres, and where Chapter 3 2 § states that protection is required against electric shock from indirect contact, the following applies.

In that part of the building used for the purposes described in the first paragraph, additional protection shall be provided for socket outlets with a maximum current rating of 16 A. The additional protection shall consist of a residual current device with a maximum sensitivity rating of 30 mA. The residual current device shall protect against faults in the underlying protection system and the carelessness of the user. However, if a loss of power to a socket outlet might have serious consequences the socket outlet may be omitted from the additional protection.

Chapter 5 Special safety requirements for high voltage installations

1 § Exposed parts of a high voltage installation shall be earthed, as shall any extraneous conductive parts which, in the event of a fault, through induction or magnetisation, could become live and present a risk of injury or damage.

Outside restricted access locations, equipment and cables shall either have an earthed enclosure or be protected from accidental contact by virtue of its position. Earthed enclosure is taken to mean a metal enclosure for equipment and shielding for cables.

2 § Protection from direct contact of a high voltage installation by means of a barrier is permitted in restricted access locations. Bars, chains and ropes shall not constitute a barrier.

3 § A high voltage installation in a non-directly earthed system shall be executed such that single or multi-pole earth faults are disconnected quickly and automatically. There is an exception in the case of an installation for a maximum nominal voltage of 25 kV not containing overhead lines. An installation of this kind may be executed such that a single pole earth fault is merely signalled automatically.

4 § In the case of a high voltage installation in a non-directly earthed system and containing

- an uninsulated overhead line of the reinforced type,
- an uninsulated overhead line with plastic coated conductor, or
- an overhead line using cable without a metal sheath or shield, the residual current device shall have the maximum possible earth fault detection sensitivity. The relay function for disconnection shall be guaranteed for impedance values up to 5000 ohm.

5 § In the case of a high voltage installation in a non-directly earthed system for a maximum nominal voltage of 25 kV, containing overhead lines of a type other than those set out in 4 §, the residual current device shall be configured such that the relay function for disconnection is guaranteed for impedance values up to 3000 ohm. In areas not covered by a detailed zoning plan, an installation of this kind shall contain a small number of spans of uninsulated overhead line with plastic coated conductor.

6 § The values set out in table 1 relate to the energising of earthed parts in installations within a non-directly earthed system for a maximum nominal voltage of 25 kV where an earth fault can occur.

Table 1 Maximum permitted values for energising of earthed parts

Part of installation	Maximum permitted values for single pole earth fault		
	Disconnected automatically within		Signalled automatically
	2 seconds	5 seconds	
Protective earth and PEN conductors belonging to another wiring system connected via a transformer in which one of the points is directly earthed (TN system) - shared earth - separate earths			
	100 V	100 V	50 V
	200 V	200 V	100 V
Exposed parts in restricted access locations or well-frequented places	400 V	300 V	100 V
Other parts	800 V	600 V	200 V

7 § In installations with a nominal voltage above 25 kV in a non-directly earthed system, earth potential rises occurring in the presence of an earth fault shall be equalised. Alternatively, the energising of earthed parts caused by the earth fault current shall be limited to the values in table 1.

General advice

The voltage and earth potential should be measured and monitored. Note that the earth potential in a non-directly earthed system is considered to be equalised if the voltages occurring do not exceed 150 V in the presence of an earth fault that is disconnected within 5 seconds, or 240 V in the presence of an earth fault that is disconnected within 2 seconds.

The voltages can be determined as the product of a 3000 ohm impedance and the current flowing through the impedance in the presence of an earth fault.

8 § A high voltage installation forming part of a directly earthed system shall be executed so that earth faults are disconnected automatically within a maximum of 0.5 seconds and the earth potential rises occurring in the presence of an earth fault are equalised.

General advice

The voltage and earth potential should be measured and monitored. Note that the earth potential in a directly earthed system is considered to be

equalised if the voltages occurring do not exceed 600 V in a restricted access location or the immediate surroundings.

The voltages can be determined as the product of a 3000 ohm impedance and the current flowing through the impedance in the presence of an earth fault.

Chapter 6 Special safety requirements for overhead lines

1 § In an area covered by a detailed zoning plan, an uninsulated overhead line for high voltage shall be executed as an unbreakable line or a line of the reinforced type if the maximum nominal voltage is 25 kV.

2 § Overhead lines belonging to multiple owners shall if possible be installed on separate masts.

3 § of the National Electrical Safety Board's regulations and general advice on owners' surveillance of electrical installations and electrical devices (ELSÄK-FS 2008: 3) contains provisions on the coordination of maintenance activities, etc. when lines belonging to multiple owners are installed together.

3 § The minimum height above ground shall be no less than the values in table 2.

Table 2. Minimum height above ground in metres

Line type and nominal voltage	Area covered by a detailed zoning plan	Area not covered by a detailed zoning plan
Overhead line ≤ 1 kV	4.5	4.5
Overhead line without metal sheathed or shielded cable > 1 kV	6*	6
Overhead line with metal sheathed or shielded cable > 1 kV	6*	4.5
Phase conductor in uninsulated overhead line		
>1 and ≤ 55 kV	7	6
> 55 kV	7 + S	6 + S
Longitudinal earth conductor	6*	4.5*

The values marked with * indicate the clearance in all load cases. The other values apply with the conductor at maximum temperature in still air. S is the voltage supplement.

Table 3. Examples of the voltage supplement (S) in metres. The values are rounded.

Nominal voltage kV	Voltage supplement (S)	
	Directly earthed system	Non-directly earthed system
77		0.2
132	0.4	
220	0.8	
380	1.7	

In tables 2, 4 and 5 the voltage supplement is 0.7 cm in a non-directly earthed system and 0.5 cm in a directly earthed system for each kV by which the nominal voltage exceeds 55 kV.

4 § Where an overhead line for low voltage enters a building, the height above ground is reduced to a minimum of 3.5 metres for uninsulated overhead lines and cables.

The height above ground of an overhead line for high voltage may be reduced where it enters a building if the line has a metal sheathed or shielded cable.

5 § An overhead line for low voltage may be routed over or next to a building provided it cannot be reached from windows, balconies or the roof without special tools.

An overhead line for high voltage may not be routed over a building. There are exceptions for

- a. metal sheathed or shielded cables,
- b. uninsulated overhead cables in restricted access locations, and
- c. uninsulated overhead cables over small non-electrified buildings provided adequate safety can still be achieved. Safety is assessed on the basis of the size of the building, the distance to the nearest phase conductor, the nominal voltage of the line and its execution.

An overhead line for high voltage shall be configured such that the horizontal distance between the conductors and a building or part of a building is at least as set out in table 4. There is an exception for an overhead line executed with metal sheathed or shielded cable.

Table 4. Minimum horizontal distance in metres between phase conductor and nearest part of a building

Area	Nominal voltage	In still air	At maximum swing
Area covered by a detailed zoning plan	>1 and ≤ 55 kV	5	3
	>55 kV	10	3 + S
Area not covered by a detailed zoning plan	>1 and ≤ 55 kV	5	3
	>55 kV	5 + S	3 + S

The table does not apply where the line enters a building. S is the voltage supplement, see 3 §.

General advice

The small buildings mentioned in c) in the second paragraph are taken to mean small outbuildings, small greenhouses, basements, etc.

6 § An overhead line shall be routed an adequate height over a thoroughfare. See table 5.

Table 5. Minimum height over a thoroughfare in metres

Line type and nominal voltage	Road		Rail		Navigation
	Public road	Other road	Rail in non-electrified railway	Rail in electrified railway	Mean high water
Overhead line ≤ 1 kV	6*	6*	8*	Not permitted	6*
Overhead line > 1 kV	6*	6*	7*	The minimum height is determined case-by-case in consultation with the railway owner	7
Phase conductor in uninsulated > 1 and ≤ 55 kV	7	6*	8		7
> 55 kV	7 + S	(6 + S)*	8 + S		7 + S
Longitudinal earth conductor	6*	6*	7*		7

The values marked with * indicate the clearance in all load cases. The other values apply with the conductor at maximum temperature in still air. S is the voltage supplement, see 3 §.

An overhead line in a navigable area shall be installed at the minimum height above mean high water shown in table 5.

14 § of the Swedish Heavy Current Ordinance (2009:22) contains other provisions relating to overhead lines in a navigable area. 9 § of that ordinance contains further provisions relating to the duty to notify the Swedish Transport Agency when work starts or ends on heavy current lines in a navigable area.

If an overhead line crosses an electrified railway, it shall be installed at the height specified by the National Electrical Safety Board in consultation with the railway owner.

7 § An overhead line for high voltage other than a metal sheathed or shielded cable shall be routed an adequate distance from well-frequented

places, e.g. school grounds, sports fields, camp sites, swimming pools and playgrounds.

An overhead line may be routed over areas used for leisure activities which do not normally have spectator areas, e.g. golf courses, provided that steps have been taken to prevent damage to the line and that the line is executed as an unbreakable line or, if the maximum nominal voltage is 25 kV, a line of the reinforced type.

General advice

An adequate distance is normally taken to mean that the horizontal distance between a live conductor and the place is no less than 20 metres.

8 § An overhead line for high voltage other than a metal sheathed or shielded cable shall be routed an adequate vertical and horizontal distance from car parks.

The distance necessary to ensure adequate safety for car parks is assessed on the basis of the type of vehicles intended to use the car park and whether vehicles used to transport explosive or flammable goods may be parked there.

General advice

In the assessment of the horizontal distance necessary to provide adequate safety for car parks, guidance can be found in table 4 concerning the distance to buildings and table 6 concerning the distance to vehicles carrying flammable or explosive goods.

9 § An overhead line shall be routed an adequate distance from shooting ranges.

The distance necessary to ensure adequate safety for shooting ranges is assessed on the basis of the layout of the shooting range and how it is used. The assessment shall include the distance at the sides, the horizontal distance behind the firing line and behind the backstop, and how clearly visible the line is from the firing line.

10 § An uninsulated overhead line shall be routed an adequate distance from stores of combustible material and areas where there is a risk of explosion.

General advice

The dimensions in table 6 may be used as guidance in assessing what is considered to be an adequate distance to an area where there is a risk of explosion.

Table 6. Minimum horizontal distance in metres from a live conductor to an area with a risk of explosion.

Design voltage kV	Distance to a danger zone with flammable goods with regard to the risk of electrostatic charge	Distance to a store of explosive goods
12.0 - 72.5	15	50
82.5	30	50
145 - 170	30	100
245	45	100
420	60	100

Design voltage is taken to mean the maximum operating voltage for installations and equipment.

Chapter 7 Special safety requirements for contact line installations for railway, light rail, underground railway and trolley bus operation

1 § A track area for underground railways with a conductor rail shall be adequately enclosed or fenced off. Only skilled persons or persons who have received instruction on the risk of injury or damage caused by electricity shall be given access to the track area.

2 § The minimum height above top of rail or above the road surface for trolley buses shall be no less than 5.0 metres.

At road bridges, tunnels, etc. the minimum height of the contact line may be reduced to 4.8 metres in the case of a high voltage installation and 4.2 metres in the case of a low voltage installation.

The second paragraph does not apply to the contact lines described in Commission Decision of 30 May 2002 (2002/733/EC) concerning the technical specification for interoperability relating to the energy subsystem of the trans-European high-speed rail system referred to in Article 6(1) of Directive 96/48/EC.

3 § A contact line shall be routed such that the distance between live parts and a building or part of a building, which the does not enter, is at least 5 metres in still air.

However, a contact line which is an uninsulated overhead line for a maximum nominal voltage of 750 V may be routed closer to buildings provided it cannot be reached from windows, balconies or the roof without special tools.

Notwithstanding the first paragraph, the horizontal distance may be reduced

- a. to 3 metres in the case of operational buildings,
- b. to 0.5 metres in the case of operational building occupying a surface area of up to 10 m² provided the building has a distance of at least 4 metres to the contact line and a horizontal distance to the nearest mast of at least 4 metres, and
- c. in the case of platform canopies, to a distance considered to provide adequate safety taking account of the pantograph on vehicles and of any work to be carried out on the canopy.

The exception in c) in the third paragraph only applies if unauthorised access to the platform canopy is impossible.

General advice

If a contact line is routed close to a building which is significantly higher than the contact line, special safety measures are sometimes required. However, there is no need for any special protection if no part of the building is closer to the contact line than indicated by the boundary lines A-B-C-D in the figure below showing a section of track with a contact line for a nominal voltage above 750 V.

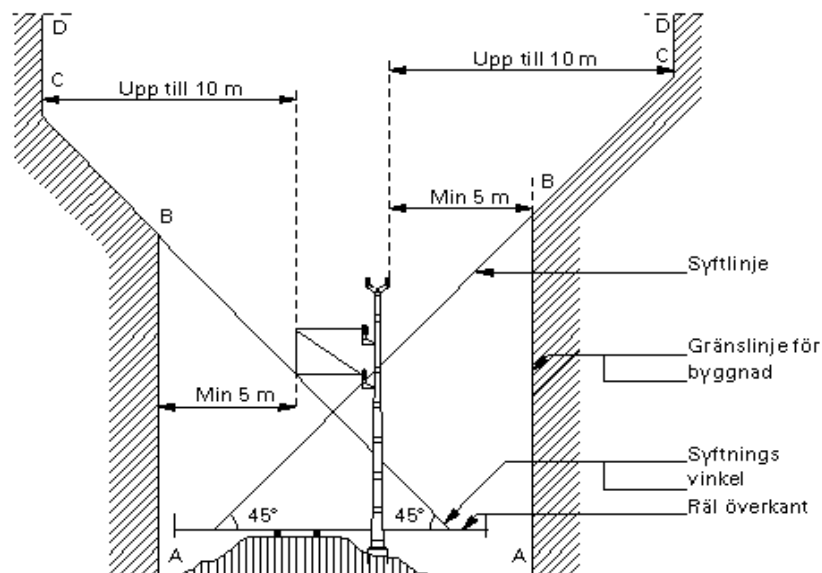

4 § An contact line shall be routed an adequate distance from stores of combustible material or areas where there is a risk of explosion.

General advice

The dimensions in Chapter 6 10 § table 6 may be used as guidance in assessing what is considered to be an adequate distance to an area where there is a risk of explosion.

5 § A contact line shall be routed such that the horizontal distance between a live part and a road verge is at least 4 metres.

6 § At a grade crossing between a railway contact line and a public road, there shall be portals on both sides of the railway with a lower edge at least 4.7 metres above the road surface.

The contact line shall be installed at least 0.5 metres (low voltage) or 0.8 metres (high voltage) higher than the lower edge of the portal. In order to allow temporary work to be carried out, the distance of 0.8 metres may be reduced to 0.5 metres.

Where there are particular reasons to do so and the road authority agrees, the height above top of rail of the contact line may be reduced to a minimum of 5.0 metres and the vertical distance between the lower edge of the portal and the road surface may be reduced to a minimum of 4.2 metres.

7 § Where a road bridge or footbridge crosses over a contact line, protection shall be provided in the form of a net or a canopy shielding the contact line if the distance between the bridge deck and the contact line is less than 5 metres.

8 § A heavy current line, light current line or mechanical line crossing a contact line for railway, light rail, underground railway or trolley bus operation shall be routed under the thoroughfare.

If the crossing line is a high voltage line it may be routed over the contact line if the span of the high voltage line is executed as an unbreakable line.

If the crossing line is a light current line it may be routed over a contact line for railway, light rail, underground railway or trolley bus operation for a maximum nominal DC voltage of 750 V provided the light current line at the crossing point is executed with reinforced insulation for 750 V and is installed in supporting line made of insulating material.

5 § of the Swedish Light Current Proclamation (1972:463) contains further provisions regarding light current cables in areas used by railways and released for public use or for light rail or underground railways under the supervision of Swedish Rail Administration.

9 § Warning signs with warnings about the railway contact line shall be placed at loading tracks, grade crossings, protective arrangements on road bridges and in railway station areas and stopping points.

A track area with a conductor rail shall be provided with signs prohibiting unauthorised access and signs warning about the electrical hazard.

10 § At grade crossings between a railway contact line and a road which is not a public road, signs shall be placed on both sides of the railway prohibiting vehicles exceeding 4 metres in height crossing the track.

11 § An electrical installation for railway, light rail, underground railway or trolley bus operation shall be executed such that damage caused by leakage current corrosion of cables, pipelines and metal objects is prevented as far as is reasonably possible.

Entry into force and transitional arrangements

ELSÄK-FS 2008:1

These regulations shall enter into force on 1 October 2008, when the National Electrical Safety Board's regulations and on the execution of electrical installations and general implementation advice (ELSÄK-FS 2004:1) shall simultaneously cease to apply.

Installations put into service before entry into force may be executed in accordance with earlier arrangements. However, if the use of such installations or the circumstances change in a way that has a significant bearing on electrical safety, the new arrangements shall be applicable.

If an installation is modified or extended, the new arrangements shall be applicable to the modification or extension regardless of when the installation was first put into service.

However, there are exceptions from the following requirements:

- The requirement in Chapter 4 1 § on protective earthing when extending a low voltage installation in an existing room in a dwelling or comparable dry room with insulating floor. – In these rooms no protective earth is necessary for the exposed parts if there is no protective earth for the existing exposed parts and the installation was executed before 1 January 1994.
- The requirement in Chapter 4 4 § on residual current devices when extending a low voltage installation in an existing dry room in dwellings, primary schools, leisure centres, kindergartens and day care centres. – In these rooms, an electrical installation may be extended without the need to install a residual current device if the existing installation was executed in accordance with ELSÄK-FS 1994:7 or equivalent earlier arrangements.
- The requirement in Chapter 5 5 § on the sensitivity of earth fault protection for high voltage installations executed as overhead lines with uninsulated conductors for a nominal voltage of 25 kV. – These overhead lines may be extended or modified with uninsulated conductors without any change to the sensitivity requirement of the residual current device.

ELSÄK-FS 2010:1

These regulations and general advice enter into force on the date of the statute as indicated by the date of printing in the Code of Statutes of the National Electrical Safety Board.

ELSÄK-FS 2015:3

These regulations enter into force on 1 November 2015